

Mary Dalrymple and Jamie Y. Findlay

## 5 Lexical Functional Grammar

**Abstract:** Lexical Functional Grammar is a linguistic theory which explores the various aspects of linguistic structure and how they are related. Like HPSG (Müller and Machicao y Priemer, 2018), Construction Grammar (Chaves, 2018), and the Parallel Architecture (Jackendoff and Audring, 2018), it is constraint-based and declarative, and does not assume that processes such as transformations are a part of linguistic theory. It was developed in the late 1970s by Joan Bresnan and Ron Kaplan as a theory of syntax, but has since been augmented by theories of other modules of linguistic structure and their relations to one another, including semantics and the syntax-semantics interface, argument structure, information structure, morphology, and prosody. These levels of structure are represented by separate grammatical modules which may be of very different formal character, connected to one another by means of functions relating parts of one structure to its corresponding parts in another structure.

Lexical Functional Grammar (LFG) is a declarative, constraint-based framework for analysing the various components of grammar, including, crucially, syntax. Although this chapter will introduce several parts of the formalism, it is not a comprehensive introduction to the theory, and the interested reader should consult one of a number of good book-length works which fill this role (Bresnan et al., 2016, and Falk, 2001, are textbooks, while Dalrymple, 2001 and Dalrymple et al., 2019 are reference works).

### 1 Data

LFG theory is built on a variety of types of linguistic evidence. In keeping with its origins in generative grammar, a common form of evidence is introspectively obtained judgements, either those of the linguist, or elicited judgements taken from others in more or less formalised (experimental) settings. However, no data type is ruled out as intrinsically irrelevant, and argumentation may make reference to experimental, corpus, or diachronic data. Furthermore, as in Construction Grammar (Chaves, 2018), no distinction is made between the “core” and the “periphery”: the theory concerns itself with the analysis of the full range of constructions and phenomena of human language.

---

**Acknowledgement:** Thanks to Louise Mycock, Adam Przepiórkowski, Ron Kaplan, John Hewson, and the volume editors for helpful comments. Part of this work was conducted during the first author’s fellowship at the Oslo Center for Advanced Study at the Norwegian Academy of Science and Letters.

In fact, LFG sprang in part from the dissatisfaction of Joan Bresnan and Ron Kaplan with what they saw as the “psychologically unrealistic” (Bresnan, 1978, 2) transformational theories developed by Chomsky and his colleagues during the 1950s, ’60s, and ’70s. In their efforts to build a mathematically well grounded linguistic theory that could underpin a psycholinguistically plausible model of human language processing, Kaplan and Bresnan adopt what they call the ‘Competence Hypothesis’:

We assume that an explanatory model of human language performance will incorporate a theoretically justified representation of the native speaker’s linguistic knowledge (a *grammar*) as a component separate both from the computational mechanisms that operate on it (a *processor*) and from other nongrammatical processing parameters that might influence the processor’s behavior. To a certain extent the various components that we postulate can be studied independently, guided where appropriate by the well-established methods and evaluation standards of linguistics, computer science, and experimental psychology. However, the requirement that the various components ultimately must fit together in a consistent and coherent model imposes even stronger constraints on their structure and operation. (Kaplan and Bresnan, 1982, 173)

One of the aims of LFG is therefore to create a more psychologically plausible model of the grammar, one which takes seriously the role of processing in grammatical analysis. This is part of the motivation for LFG as a declarative/constraint-based framework.

Corpus data is also an important basis for theoretical claims in LFG. Indeed, corpora can serve as vital testing beds for evaluating computational implementations of the theory. This combination of theoretical and computational perspectives is crucial because large-scale computational grammars very quickly become far too complex to be assessed holistically by hand. Dyvik et al. (2009) and Patejuk and Przepiórkowski (2015) discuss large-scale annotated corpora and their use in the development and testing of computationally implemented LFG grammars.

Theoretical claims are also made on the basis of historical data; Coppock and Wechsler (2010), for example, advocate an analysis of person agreement in the Uralic languages based on the historical path from incorporated pronoun to agreement marker. This makes use of work which describes grammaticalisation in terms of the loss of LFG features (Bresnan and Mchombo, 1987).

‘Performance’ data has also been important in the development of LFG-DOP, a combination of Data-Oriented Processing (Bod, 1992) with LFG. DOP models assume that “human language perception and production work with representations of concrete past language experiences, rather than with abstract grammatical rules” (Bod and Kaplan, 1998, page 145). In general, DOP works by taking a corpus of linguistic representations and decomposing them into fragments, which are then recomposed in the analysis of new utterances. The LFG-DOP model specialises the theory to a corpus of LFG syntactic representations. Although not part of ‘mainstream’ LFG work, LFG-DOP shows the possibility of combining LFG with other approaches, a theme which will reoccur in our discussion.

## 2 Goals

A fundamental assumption of LFG is that the language faculty is made up of multiple, inter-dependent modules, which exist in parallel and are mutually constraining. Language is not a unitary object, and the best way to describe and explain properties of, say, phonology, will not necessarily be the same as to explain syntax. This much is perhaps relatively uncontroversial (although it is at odds with the ‘syntacto-centrism’ of much generative linguistics, which sees other components, especially semantics, as ultimately parasitic on a syntactic level of representation—cf. the notion of Logical Form as a level of syntax: May 1985, Hornstein 1995). Even within syntax, though, we are not dealing with a single set of formally equivalent phenomena: the term ‘syntax’ is used to describe both superficial phenomena such as word order, as well as more abstract phenomena such as subjecthood. LFG therefore proposes to separate syntactic representation into the two levels of *constituent structure* (c-structure) and *functional structure* (f-structure), the former using a familiar phrase structure tree to represent linear order as well as hierarchical structure and constituency, the latter using a feature structure (also known as an attribute-value matrix) to represent abstract relational information about grammatical functions, binding, long-distance dependencies, etc.

(1) Constituent structure:                      Functional structure:

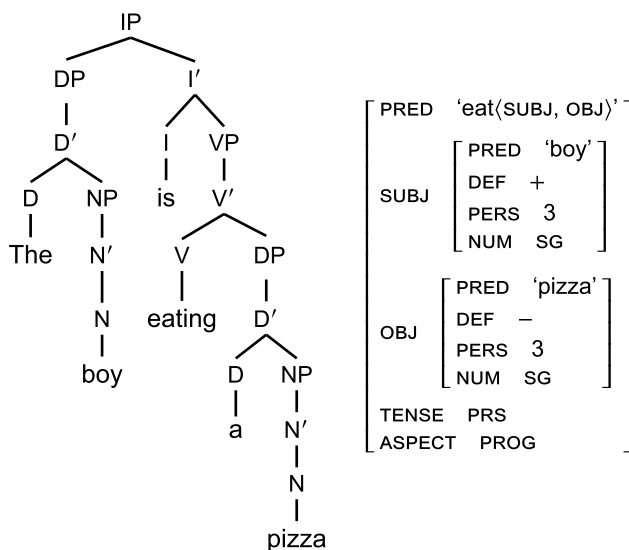

Bresnan sums up the view in this quotation:

Semantic argument structure, constituent structure and functional structure are parallel information structures of very different formal character. They are related not by syntactic derivation, but by structural correspondences, as a melody is related to the words of a song. Semantic, structural and functional representations of a sentence can be superimposed, but they are independent planes of grammatical organisation. (Bresnan, 1993, 45)

The central challenge for this kind of approach is determining the modules relevant for linguistic analysis, their internal structure and constraints, and the relations between them. This is a large part of what modern work in LFG involves. However, in general the two syntactic modules, c- and f-structure, have remained central to LFG theorising since the beginning. Since the topic of the present volume is syntax, this is where our focus will lie as well.

## 2.1 Well-formedness criteria

LFG is, true to its generative roots, interested in describing linguistic competence as opposed to performance: that is, the knowledge that one possesses in knowing a language as opposed to what is required in order to deploy that knowledge in production or comprehension. For this reason, LFG as a grammatical theory does not encompass performance factors (although LFG-based theories of performance can be formulated, such as LFG-DOP, mentioned in Section 1), and so what are taken as data for analysis tend to be ‘cleaned up’, abstracting away from various performance ‘noise’ factors such as hesitations, repetitions, speech errors, etc.

In keeping with the usual approach in generative syntax, traditional LFG work treats well-formedness as categorical. That is, sentences (or, rather, linguistic descriptions) are either a part of the grammar or are not. There is no notion that some grammatical violations are ‘better’ or ‘worse’ than others. For example, a simple failure of agreement like (2) is just as ungrammatical as utter nonsense such as (3):

- (2) \* Kim see the painting.
- (3) \* Dog flarb the on ktaw.

Of course, there is nothing preventing us from devising other metrics, such as how many constraints a description violates, which can give us a derivative notion of grammatical gradience.

One strand of work which has sought to add a notion of gradience to the LFG understanding of well-formedness is Optimality-Theoretic LFG (OT-LFG: Bresnan, 2000, 2002; Kuhn, 2001), a variant of OT syntax where the output of the GEN component consists of pairs of c-structures and f-structures. In OT-LFG, in keeping with the general principles of OT (Prince and Smolensky, 2004; Legendre, 2018), the grammar consists of a set of possibly incompatible, violable constraints, where a linguistic description need not satisfy all of the constraints in order to be well-formed, but must merely be the ‘least bad’ candidate description. Such a system allows for a much more fine-grained analysis of well-formedness. For example, it makes it possible to describe levels of *ungrammaticality*: a sub-optimal candidate can still be ranked above other sub-optimal candidates, by violating fewer highly-ranked constraints, and can therefore be ‘less ungrammatical’ in a well-defined sense. This can explain the reported observations that speakers are sensitive to distinctions even among clearly ungrammatical examples (Featherston, 2008).

## 2.2 Relations to other grammatical modules

Given the central LFG assumption that language is modular and composed of multiple, internally complex subsystems, syntax is not, in a theoretical sense, privileged. In a practical sense, however, most work in LFG has been of a syntactic nature, and the framework did start life primarily as a model of syntax.

However, as we have seen, ‘syntax’ is not a single component of the grammar, but is rather sub-divided into two modules: c-structure, which represents word order and phrasal grouping, and f-structure, which represents grammatical functions and features. Kaplan (1987) proposed to generalise this view and extend it to other components of the grammar, such as semantics or phonology: different grammatical modules have their own internal structure and organisational principles, and are related via structural correspondences relating components of one module to components of other modules. Asudeh (2006) describes this *correspondence architecture* in more detail.

This means that the grammar as a whole—syntax, semantics, information structure, prosodic structure, etc.—is a “nearly decomposable system” in the sense of Simon (1962), where the internal organisation and behaviour of each component is largely independent, but relations among the components can be defined so that units of one component are related via correspondence to units of another. For example, just as the c-structure nodes of the subject of a sentence are related to the subject f-structure, in the same way an f-structure is related to the semantic structure corresponding to its meaning.

Current LFG work builds on this view, with an exploration of syntax (in its dual nature, c-structure vs. f-structure) and its relation to semantics, information structure, and phonology, and also defining the place of morphology in the overall architecture. A schematic version of the full correspondence architecture is given in (4):<sup>1</sup>

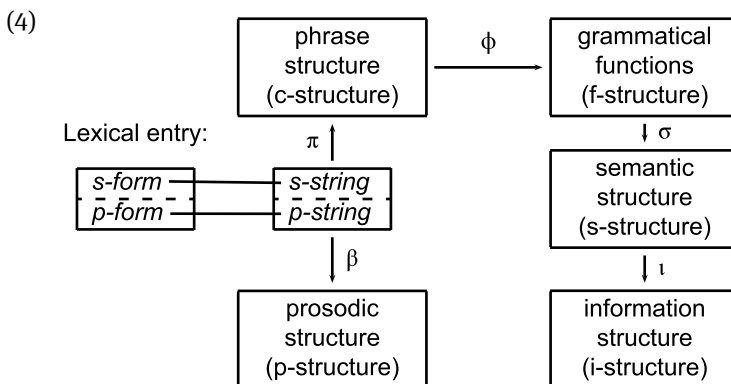

<sup>1</sup> Some scholars assume an independent level of argument structure between c- and f-structure (Butt et al., 1997), but recent work has represented this information at semantic structure instead (Asudeh and Giorgolo, 2012; Findlay, 2016).

The morphological component generates lexical entries (Sadler and Spencer, 2001; Kaplan and Butt, 2002; Dalrymple, 2015). As shown in (4), a lexical entry encodes constraints on an s-form (the terminal node of the phrase structure tree and the grammatical and semantic constraints associated with it) and a p-form (which forms the basis of prosodic analysis). Thus, the lexicon is the locus of the relation between syntax/semantics and phonetics/phonology (Mycock and Lowe, 2013; Dalrymple et al., 2019). This allows the analysis of strings of words (sentences), which are connected to both a prosodic structure (Dalrymple and Mycock, 2011; Mycock and Lowe, 2013) and a syntactic constituent (c-)structure. Functional structure is related to c-structure via a function called  $\phi$  (on which see Section 3.3), and f-structure is in turn related to semantic structure (Dalrymple, 1999; Asudeh, 2012) and information structure (Dalrymple and Nikolaeva, 2011; Dalrymple et al., 2019).

Owing to its modularity, LFG as a syntactic theory is agnostic about which particular theory one adopts for any of the other levels of structure (phonetics and phonology, semantics, morphology, etc.). In general, work on phonetics and phonology *per se* has been limited. Work on prosody has most often assumed an independent hierarchical prosodic structure, governed by the Prosodic Hierarchy of Prosodic Phonology (Selkirk, 1981; Nespor and Vogel, 1986).

Work on semantics is much more developed. The most common theory of the syntax-semantics interface in LFG is Glue Semantics (Dalrymple, 1999; Asudeh, 2012). In Glue, meaning composition is treated as deduction in a resource logic: the meaning of a sentence is assembled from the meaning of its parts via logical deduction. LFG+Glue remains agnostic about what particular ‘meaning language’ is used to actually express the natural language meanings themselves. Practitioners commonly use some variety of predicate calculus, but there is work which uses Discourse Representation Theory (van Genabith and Crouch, 1999; Bary and Haug, 2011; Lowe, 2012), Natural Semantic Metalanguage (Goddard and Wierzbicka, 2002; Andrews, 2006), and others.

## 2.3 Domain of analysis

The main focus of LFG, like other theories in the generative tradition, is the sentence level. However, work on larger domains is not excluded: for example, King and Zaenen (2004) and Dalrymple et al. (2017) offer analyses of discourse structure and inter-sentential anaphora within the LFG framework. Giorgolo and Asudeh (2011) also give a proposal for integrating gesture into the correspondence architecture, thus extending the coverage of LFG to other modalities beyond speech.

As well as larger, discourse-level issues, however, one must not neglect the importance of sub-sentential units. One of the strengths claimed for LFG from the start, as for other constraint-based, non-transformational theories including HPSG (Müller and Machicao y Priemer, 2018), is its ability to give an account of fragments and partial

sentences (Kaplan and Bresnan, 1982), which are vitally important in terms of understanding acquisition and processing. Such a property emerges in LFG largely thanks to the local character of most constraints, unlike in Minimalism (Hornstein, 2018), for example, where features may not be checked until much higher up in the tree than they are introduced.

## 2.4 Language domain

Descriptions of individual languages' grammars are intended to be full and accurate accounts of a single, synchronic state of the language. However, when it comes to deeper questions of theory, cross-linguistic data is invaluable, as well as data about the historical evolution of languages.

LFG takes grammatical functions to be theoretical primitives, and assumes that the stock of such functions forms the basic vocabulary of functional structure. Cross-linguistic data has been crucial in reaching this conclusion: for example, Kroeger (1993) demonstrates the importance of the role of subject even in languages like Tagalog which have been argued not to make use of it (Schachter, 1976).<sup>2</sup>

Although most LFG work is synchronically oriented, an important strand of work relies on LFG assumptions in explanatory accounts of historical change, taking advantage of LFG's separation between phrasal structure and abstract functional structure. For example, Allen (1995, 2008), Bresnan and Mchombo (1987), Börjars et al. (1997) and Vincent (1999) discuss how grammaticalisation can be understood in terms of the loss of f-structure information.

The less restrictive LFG conception of phrase structure has also been important in historical work: Vincent (1999), Börjars et al. (2016) and Börjars and Vincent (2016), for example, take advantage of LFG's ability to incorporate not only  $X'$ -theoretic categories but also non-projecting categories and exocentric categories in the phrase structure in their analysis of the introduction and development of closed-class words such as prepositions and determiners, which may start out as non- $X'$ -theoretic words, but which later evolve to full  $X'$ -theoretic status, appearing as the head of a phrase with specifiers and complements. For further examples of LFG-based diachronic work, see the papers collected in Butt and King (2001).

## 2.5 Applications

LFG as a linguistic theory is not specifically aimed at solving practical problems, but it has been used as the basis or grammar component of several systems and theories which have a more practical application.

---

<sup>2</sup> See Falk (2006) for a contrasting view on the primacy of SUBJ as a theoretical primitive.

Computational implementation has been an important aspect of LFG research from the start. One of the earliest LFG implementations was the Grammar Writer's Workbench (Kaplan and Maxwell, 1996), originally implemented in the early 1980s. In 1993, the team at the Xerox Palo Alto Research Center (Xerox PARC) began work on a new implementation, which ultimately became the Xerox Linguistic Environment (XLE: Crouch et al. 2008; Maxwell 2015).

Within XLE, a major focus has been cross-linguistic application. The Parallel Grammar Project (PARGRAM: Butt et al. 1999, Butt et al. 2002) is a prime example of this. The project started in 1994 with grammars of English, French, and German, and later grew to include grammars of Norwegian, Japanese, Urdu, Turkish, Hungarian, Georgian, Tigrinya, Wolof, Indonesian, Welsh, Malagasy, Mandarin Chinese, Arabic, Vietnamese, Polish, and Northern Sotho.

In general, the availability of computational implementations of LFG, and in particular the XLE, has led to productive research on combining LFG grammars with other computational tools to increase parsing efficiency, improve parsing results, or produce more useful language-based applications.

A different kind of practical application for LFG is found in the domain of second language acquisition. Processability Theory (Pienemann, 1998, 2005; Bettoni and Di Biase, 2015) takes LFG as its formal model, and makes crucial use of the division among grammatical modules assumed by LFG in its treatment of second language acquisition.

## 3 Tools

LFG is a formalised framework, and this means that all levels of representation have well-defined mathematical properties, and are subject to explicit well-formedness conditions. In this section, we introduce the two syntactic levels assumed in all LFG work, constituent structure (c-structure) and functional structure (f-structure).

### 3.1 C-structure

LFG departs from Chomskyan approaches in seeing the locus of cross-linguistic similarity not as c-structure but as f-structure (for more on which, see Section 3.4 below), taking traditional grammatical terms such as *subject* and *object* not as derivable from constituent structure, but rather as theoretical primitives in their own right. This means that no constituent structure is privileged as underlying or 'deep' in any sense: surface word orders are purely a matter of language-specific phrase structure rules.

For this reason, when it comes to describing the c-structure of a language, the focus is on analyzing just those phenomena which are best represented explicitly by



phrase structure trees, notably word order and hierarchical structure, but also syntactic category, since we assume that the nodes in such a tree are labelled. Constituency relations are also expressed here, given that constituency can be understood as exhaustive dominance.

An example of a c-structure is given in (5):

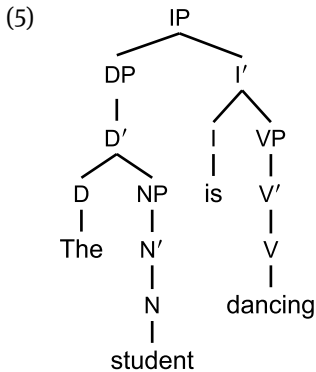

Formally, c-structures are described via a simple context-free grammar, where the phrase structure rules are understood not as rewrite rules but as *node admissibility conditions* (McCawley, 1968), which describe the set of trees admitted by the theory. LFG subscribes loosely to *X' theory* (Jackendoff, 1977), so that there are three levels of projection described with respect to the head of a phrase,  $X: X^0$  (or simply  $X$ ; the head itself),  $XP$  (the maximal, phrasal projection), and  $X'$  (all intermediate levels). This provides the following schematic positions in relation to  $X$  (ignoring linear order):

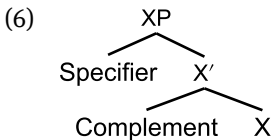

In configurational languages like English, phrases filling these positions have particular functional roles (as suggested by their names), and this is no doubt in part why some theories conflate the abstract properties of syntax with the overtly manifested ones. For example, such theories might say that all subjects appear in the specifier of IP. However, such a correlation between position and function is far from necessary, and in reality only represents one end of a spectrum of possibilities in which “morphology competes with syntax” (Bresnan, 1998). That is, in a language such as Latin or Warlpiri, where relational information is indicated by case, word order tends to be governed by other communicative concerns (such as information structure), and thus is a poor guide to grammatical relations. In transformationalist theories, this leads to the claim that there is a confluence at some other point in a derivation—perhaps there

is a ‘deep’ or underlying structure where grammatical relations are manifested configurationally, or perhaps such correspondences do not emerge until later on in the derivation. In contrast, LFG simply assumes that such functional information is best represented at a different level of structure, since it is not inherently configurational.

Although we do not assume that functional information is defined configurationally, there do undoubtedly exist correlations between certain phrase structure positions and certain grammatical functions (Bresnan et al., 2016). Nevertheless, languages vary widely in the kinds of syntactic configurations they permit, and thus LFG allows them to vary relatively freely in the kinds of phrase structure rules they contain, and thereby the kinds of trees they admit. C-structure constraints are thus much less stringent in LFG than in some other formalisms; LFG adheres only loosely to  $X'$  theory.

Similarly, we do not require the presence of empty categories in the c-structure tree. For example, while LFG is compatible with a theory of long-distance dependencies that posits traces (Kaplan and Bresnan, 1982; Bresnan, 1995, 1998), they are not required (Kaplan et al., 1987; Kaplan and Zaenen, 1989; Dalrymple et al., 2007), nor are other unpronounced elements such as *pro/PRO*. Instead, such elements are represented at f-structure when required.

What is more, where there is no strong evidence for the existence of a particular hierarchical structure, we do not feel constrained to nonetheless posit it. For example, in ‘free word order’ languages, LFG makes use of the exocentric category S, permitting a flat structure when there is no evidence for a more articulated one:

- (7) Tharrkari (Austin and Bresnan, 1996, 248):

Pudhi-langu ngadha nhurra-nha wana-ku.  
hit-MIGHT I.NOM you.SG-ACC fighting.stick-ERG

‘I might hit you with a fighting stick’

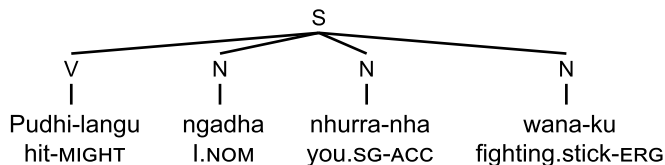

In addition, where a verb has more than one complement, trees do not have to be binary branching:

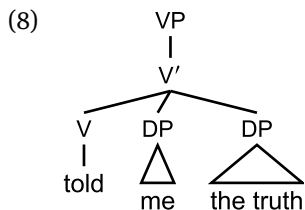

This avoids the requirements of heavily articulated trees with unpronounced functional elements which a theory restricted to purely binary branching necessitates (Kayne, 1984). C-structure represents words and their grouping into constituents, not abstract functional features and relations.

Another way in which LFG c-structures differ from familiar  $X'$ -theoretic trees is in the optionality of all positions. That is, there can be phrases without heads (and, in some versions of the theory, heads without phrases—the so-called non-projecting categories of Toivonen, 2003). For example, in an English sentence without an auxiliary verb to occupy I, we do not need to posit an unpronounced feature appearing in the tree which expresses tense, nor do we need to separate the main verb so that its tense ending appears at I and ‘lowers’ to the main verb, since in such cases tense is expressed by the finite verb in V. Instead, we have the structure in (9), where the head simply does not appear:

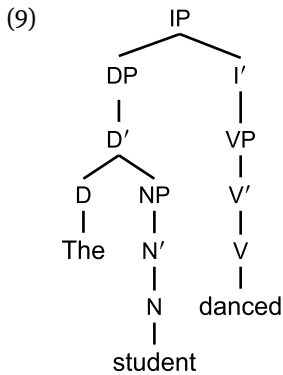

Finally, some practitioners subscribe to what is called the principle of *Economy of Expression* (Bresnan et al., 2016, 89–94), whereby all nodes are omitted unless motivated by some functional requirement. Under this approach, in (9) there would be no  $N'$  and no  $V'$ , since there is no evidence for their existence. Where the structural configuration provides important information, though, the node remains: thus, the  $I'$  would remain in our example because the fact that the DP *the student* appears as its sister is what tells us, in English, that this DP is the subject (for more on which see Section 3.3). For further discussion of Economy of Expression, see Dalrymple et al. (2015).

The set of syntactic categories generally assumed is fairly conservative. Almost all LFG practitioners agree on the following inventory of categories and their projections, along with the exocentric category S:

- (10) Lexical categories: N, V, P, Adj, Adv  
 Functional categories: C, I, D

Other categories are used occasionally, such as K for case (Butt and King, 2004), but the extended functional projections of other theories are not appealed to, since functional information is represented separately, in f-structure.

### 3.2 F-structure

The point just made once again illustrates the separation of levels held to be central in LFG: although different levels constrain and impact on each other, so that, for example, in configurational languages, word order and grammatical functions are correlated, nevertheless, *internally*, each level represents only the material which is pertinent to that level. Thus, inherently ordered, configurational properties such as word order and constituency are represented by a formal object that expresses such properties, namely the c-structure tree. More abstract, and inherently unordered, properties like grammatical relations and other functional phenomena are expressed elsewhere, namely at f-structure, which has different properties more conducive to this task. In essence, LFG does not force the data to fit the properties of a particular mathematical object, but rather chooses data structures on the basis of how well their properties fit with the observed phenomena.

An f-structure for sentence (5) is given in (11):

(11) *The student is dancing.*

$$\left[ \begin{array}{ll} \text{PRED} & \text{'dance(SUBJ)'} \\ & \left[ \begin{array}{ll} \text{PRED} & \text{'student'} \\ \text{DEF} & + \\ \text{NUM} & \text{SG} \\ \text{PERS} & 3 \end{array} \right] \\ \text{SUBJ} & \\ \text{TENSE} & \text{PRS} \\ \text{ASPECT} & \text{PROG} \end{array} \right]$$

F-structures are attribute-value matrices, which formally are understood as functions from their attributes (the left hand column, e. g. TENSE) to their values (the right hand column, e. g. PRS). Given a set-theoretic understanding of the notion of function, this means that f-structures are sets of pairs, the left-hand member of each pair being an attribute, and the right-hand member being a value (which can itself be an f-structure, as in the value of SUBJ in example 11).<sup>3</sup> Since sets are unordered, this means that the ordering of attribute-value pairs with respect to one another is irrelevant; in other words, the f-structure in (12) is identical to the f-structure in (11):

<sup>3</sup> HPSG signs appear similar to LFG f-structures, since both are represented as attribute-value matrices. They are formally quite different, however: one difference is that HPSG signs are typed, and another is that HPSG incorporates a type-token distinction which is precluded in the set-theoretic setting of LFG f-structures. See Müller and Machicao y Priemer (2018) for more discussion.

$$(12) \left[ \begin{array}{l} \text{TENSE PRS} \\ \text{SUBJ} \left[ \begin{array}{l} \text{DEF } + \\ \text{PERS } 3 \\ \text{PRED 'student'} \\ \text{NUM SG} \end{array} \right] \\ \text{ASPECT PROG} \\ \text{PRED 'dance<SUBJ>'} \end{array} \right]$$

Thus, we are not forced to impose an ordering on properties where order seems not to matter: the fact that *the student* is the subject of the sentence is not in any sense ‘prior’ to the fact that the sentence is present tense; nor, in a transitive sentence like *the student read the book*, is the fact that *the student* is the subject in any sense prior to the fact that *the book* is the object. Of course in a language like English where subjects (generally) linearly precede objects, there does seem to be a sense in which this relation of priority holds. But this is really a fact about the c-structure encodings of f-structure relationships. We wish to say that the exact same relations of subjecthood and objecthood obtain in languages where word order is different: that is, a subject is just as much of a subject in a VOS language like Malagasy as it is in an SVO language like English, the only difference being in how it is realised configurationally. In this sense, there is no ordering between different pieces of functional information, and so an unordered data structure such as the attribute-value matrix of f-structure is a more appropriate way of modelling these facts than a phrase-structure tree which is inherently ordered.

Some of the most important attributes used in LFG are the *grammatical functions* (GFs). These are abstract categories used to characterise the relations between different elements of a sentence, many of which are familiar from traditional grammars. They are taken to be theoretical primitives, that is, they are not derivable from some other property like position in the tree.<sup>4</sup> A list of the most frequently assumed grammatical functions is given in Table 1 (see also Dalrymple, 2001, 8–28, Asudeh and Toivonen, 2015). It is conventional to define the abbreviation GF as a meta-category which represents a disjunction over all the possible attributes listed in Table 1, which allows for easy reference to the full set of grammatical functions:

$$(13) \text{GF} \equiv \{\text{SUBJ} \mid \text{OBJ} \mid \text{OBJ}_\theta \mid \text{OBL}_\theta \mid \text{COMP} \mid \text{XCOMP} \mid \text{ADJ} \mid \text{XADJ}\}$$

Apart from the GFs, functional structure contains other attributes such as NUMBER or PERSON, which are proposed on an empirical basis and motivated by f-structurally defined syntactic patterns and processes such as agreement. Agreement is handled

<sup>4</sup> In certain strands of LFG research on argument structure and diathesis alternations (e. g. Bresnan and Kanerva, 1989; Butt, 1995; Kibort, 2004), the GFs are further decomposed into the features [r] (for ‘semantically restricted’) and [o] (for ‘objective’).

**Table 1:** Grammatical functions in LFG.

LFG abbreviation	Grammatical function
SUBJ	Subject
OBJ	Object
OBJ <sub>θ</sub>	Restricted/secondary object (indexed by thematic role)
OBL <sub>θ</sub>	Oblique (indexed by thematic role)
COMP	Closed sentential complement
XCOMP	Open sentential complement
ADJ	Adjunct
XADJ	External (open) adjunct

at f-structure rather than c-structure because it makes reference to f-structure properties, such as subject and object, rather than c-structure ones, such as ‘leftmost phrase’. That is, ‘subject agreement’, making reference to functional information, is common, but ‘sentence-initial NP agreement’ or similar, making reference to configurational information, is not.

Other features such as DEFINITENESS are commonly assumed to be represented at f-structure, but it is a matter of ongoing debate to what extent such properties have purely syntactic effects, outside of e. g. semantic ones, and thus to what extent they deserve to be encoded at a level of syntactic representation like f-structure at all.

Because f-structure is where LFG represents abstract syntactic information, it is also where a lot of the heavy lifting of syntactic theory occurs; as we will see in Section 3.3, it is where, for example, agreement, ‘raising’, and long-distance dependencies are represented. An important corollary of this is the impact which f-structure has on the computational complexity of LFG. Although c-structure is only context-free, the presence of f-structure pushes grammars in the LFG framework into the context-sensitive space (the recognition task for LFG languages is, in the worst case, likely NP-complete: see Berwick, 1982).<sup>5</sup>

### 3.3 Connecting c-structure and f-structure

C-structure and f-structure are related by a function  $\phi$ , from c-structure nodes to f-structures.  $\phi$  is a potentially many-to-one correspondence. That is, more than one

<sup>5</sup> This is true of the formalism itself, which can be used to encode grammars with properties that are not required for describing human languages. LFG grammars for natural languages may be more tractable if they are constrained in accordance with linguistic data and principles. For example, Wedekind and Kaplan (2019) characterize a “ $k$ -bounded” proper subclass of LFG grammars for which the number of c-structure nodes that map to a given f-structure for any derivation of any sentence is guaranteed to be less than a grammar dependent constant  $k$ . An LFG grammar with this property is only mildly context-sensitive, which is the level of expressive power generally considered necessary for the description of natural language syntax (Joshi, 1985).

c-structure node can correspond to the same f-structure:

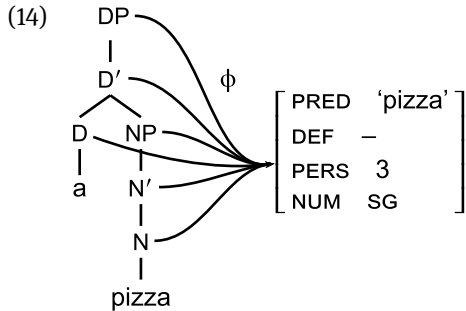

As shown in (14), the DP, D', and D nodes in each DP correspond to a single f-structure, and the projections of N also correspond to this same f-structure (we say that the NP is an *f-structure co-head* of the DP).

Similarly, in the whole sentence, all of the verbal projections, viz. IP, I', I, VP, V', and V, correspond to the outer f-structure:

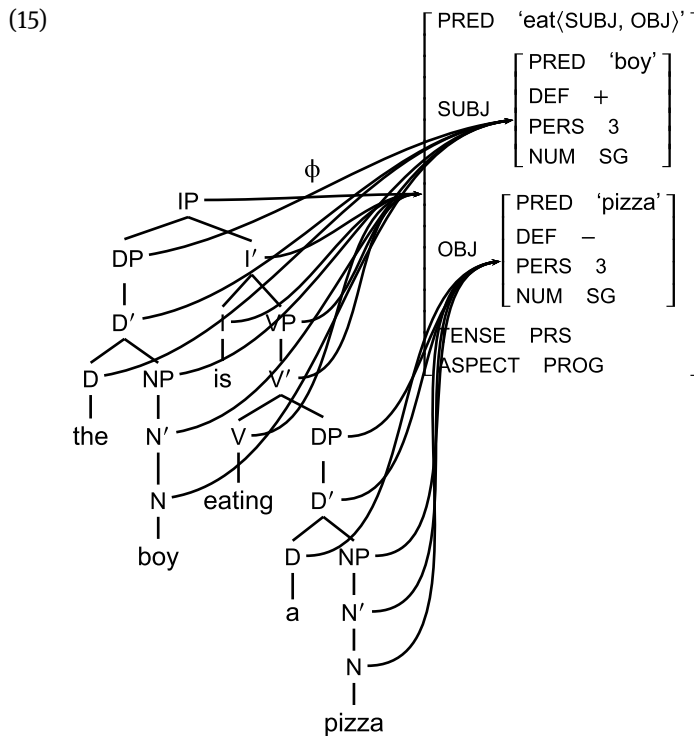

However, this quickly becomes difficult to read, and so usually we will present diagrams as in (16), where only the maximal projections have their  $\phi$  correspondence indicated:

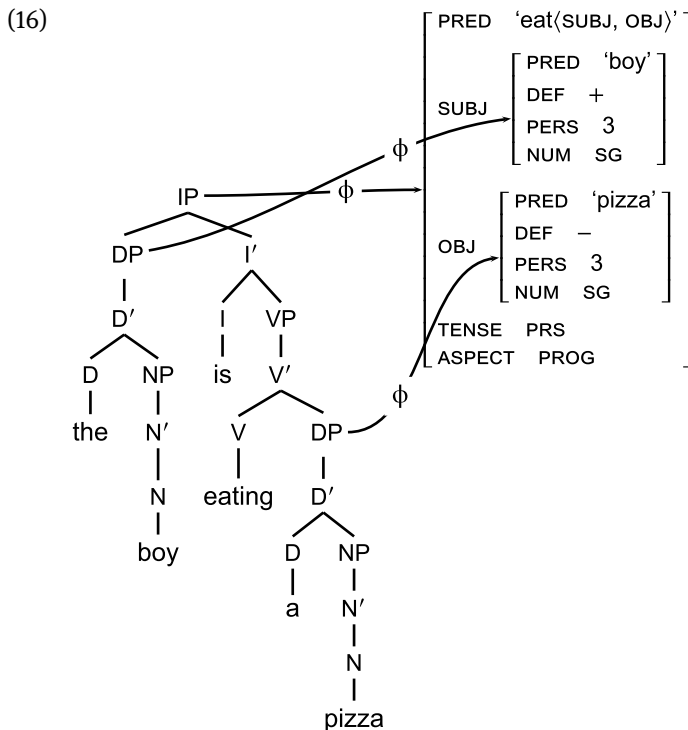

The relation between c-structure and f-structure is constrained by the function  $\phi$ : each c-structure node can correspond at most to a single f-structure. Thus, although structures in LFG are taken to be simultaneously present and mutually constraining—c-structures do not 'generate' f-structures in any sense—it is nonetheless true that there is a certain directionality encoded in the fact that such correspondences are functional. It is an empirical claim that c-structure projects f-structure, for example, rather than vice versa, based on the fact that more than one separate c-structure constituent can correspond to the same grammatical function. In the Latin example in (17), the two parts of *hae...aquae* are both part of the SUBJ, even though they appear discontinuously at c-structure, with the determiner nonadjacent to the noun.

- (17) From Snijders (2015), citing Caes. Civ. 1.50.1, via Spevak (2010, 24):

Hae permanserunt aquae dies complures.  
 these.NOM last.3PL.PERF flood.NOM.PL day.ACC.PL several.ACC

'These floods lasted for several days.'



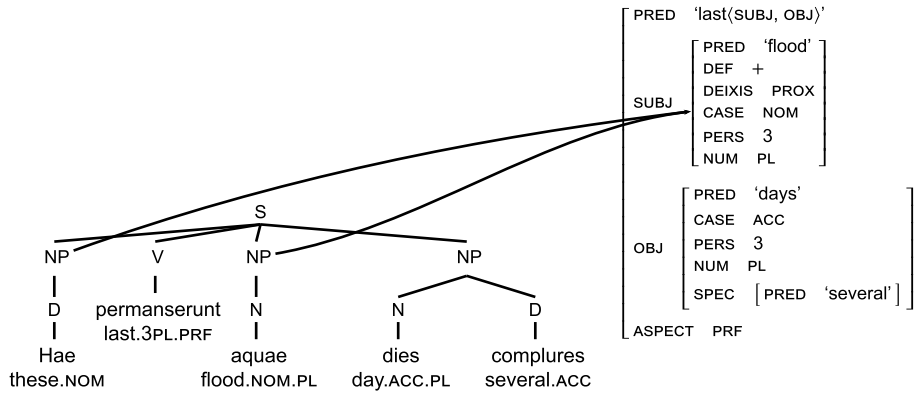

This means that more than one c-structure node can correspond to the same f-structure, but we do not have evidence of the opposite: say, a single word giving rise to two different f-structures serving as both subject and object to the same predicate. Since the correspondence relations are functions, this motivates a grammatical architecture where c-structure is mapped to f-structure, and not vice versa.

To determine the mapping which  $\phi$  describes, we annotate c-structure nodes with equations describing the relation they bear to f-structure; the f-structure which corresponds to a given c-structure is then the smallest f-structure which satisfies all of the equations. In writing these equations, we make use of the following conventions:

(18) Variables over c-structure nodes:

- a. \* refers to the current node (the node hosting the annotation).
- b.  $\hat{*}$  refers to the mother of the current node.

(19) Meta-variables over f-structures:

- a.  $\downarrow \equiv \phi(*)$
- b.  $\uparrow \equiv \phi(\hat{*})$

The asterisks refer to c-structure nodes, and the arrows refer to f-structures. In less formal terms,  $\downarrow$  refers to ‘my f-structure’, the f-structure that corresponds (via  $\phi$ ) to the node bearing this annotation;  $\uparrow$  refers to ‘my mother’s f-structure’, the f-structure that corresponds to the mother of the node bearing this annotation. The simplest equation we can write, then, is (20):

$$(20) \quad \uparrow = \downarrow$$

This says that my mother corresponds to the same f-structure as myself; this is what we use to pass information up along a non-branching c-structure, for example:<sup>6</sup>

<sup>6</sup> Annotations are written above c-structure nodes, with the intention of giving the meta-variables a kind of iconicity: the arrows point to the nodes whose f-structures they stand for. Nevertheless, many

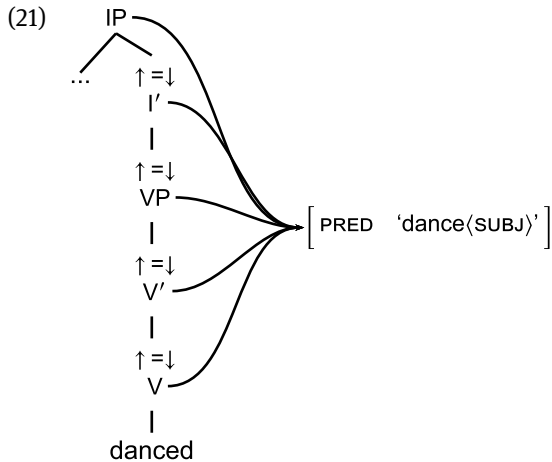

By convention, nodes that are unannotated are assumed to be annotated with the  $\uparrow = \downarrow$  equation, which enables us to reduce clutter in c-structures.

Aside from simple equality of f-structures, we can also say things about the values of particular attributes; for example that the value of the SUBJ attribute is to be found at the f-structure of the current node:

$$(22) \quad (\uparrow \text{SUBJ}) = \downarrow$$

This equation says that the f-structure corresponding to the node that bears it ( $\downarrow$ ) is the value of the SUBJ attribute of the f-structure corresponding to its mother's node ( $\uparrow$ ). It would be used, for instance, to annotate the phrase structure rule corresponding to the specifier of IP in English, which is where subjects often appear:

$$(23) \quad \text{IP} \rightarrow \begin{array}{cc} (\uparrow \text{SUBJ}) = \downarrow & \uparrow = \downarrow \\ \text{DP} & \text{I}' \end{array}$$

Such equations can also be contributed by lexical entries, and this is where idiosyncratic information such as the value of PRED attributes is encoded. Lexical entries in LFG contribute three things: a word form, a category, and a functional description, which is a set of equations describing f-structure. An example is given in (24) for past tense *danced*:

$$(24) \quad \text{danced} \quad V \quad \begin{array}{l} (\uparrow \text{PRED}) = \text{'dance(SUBJ)'} \\ (\uparrow \text{TENSE}) = \text{PST} \end{array}$$

An LFG grammar consists of a set of annotated phrase structure rules, describing the c-structure of a language and its relationship to f-structure, and a set of lexical entries

---

researchers write such annotations underneath the c-structure nodes instead; especially when multiple annotations are required, this can aid readability.

(which can in fact be thought of as phrase structure rules which simply expand pre-terminal category symbols).

Now that we have some more tools in place, we are in a position to explain how various syntactic phenomena are analysed in LFG. We start with agreement. Agreement is achieved via multiple specification: the source and target of agreement both specify values for the same features, with the result that these specifications must agree or else the structures will be ruled out as illicit by the functional nature of f-structure (which means that each attribute can only have one value). For example, a singular noun like *Alex* will specify that its number is singular and that it is third person. A plural noun like *caterpillars*, on the other hand, will specify that it is plural and third person. The third person singular verb form in English, e. g. *sings*, meanwhile specifies that its subject is third person and singular. If *Alex* is its subject, the specifications from the two items can combine successfully into a single f-structure, and thus *Alex sings* is grammatical. If it is combined similarly with *caterpillars*, though, there will be a clash when it comes to the NUMBER attribute, since this feature is simultaneously stipulated to be singular (by the verb) and plural (by the noun). Thus, \**Caterpillars sings* is not grammatical.

The (simplified) lexical entries for these three words are given below:

- (25) *sings*     V     (↑ PRED) = ‘sing(SUBJ)’  
                               (↑ SUBJ NUM) = SG  
                               (↑ SUBJ PERS) = 3
- (26) *Alex*        N     (↑ PRED) = ‘Alex’  
                               (↑ NUM) = SG  
                               (↑ PERS) = 3
- (27) *caterpillars* N     (↑ PRED) = ‘caterpillar’  
                               (↑ NUM) = PL  
                               (↑ PERS) = 3

As we can see, when *Alex* is the subject of *sings*, the assignment of a value to the subject’s NUM attribute proceeds without any problem, since both the verb and the noun specify SG as the value of that feature. When *caterpillars* is the subject, though, there will be a clash, since the noun specifies PL, while the verb calls for SG.

‘Raising’ and long-distance dependencies are represented via f-structure sharing: the same f-structure can be the value of multiple attributes. We are not merely talking about type identity here, where there are two distinct f-structures of the same form, but rather token identity, where the f-structures are one and the same. For this reason, such structure sharing is often represented using a line to connect one instance of the f-structure with its other positions—in this way, each unique f-structure is only ever represented on the page once.

The f-structure for *Alex seemed to yawn* is given in (28) (recall that XCOMP is the GF assigned to open complement clauses):<sup>7</sup>

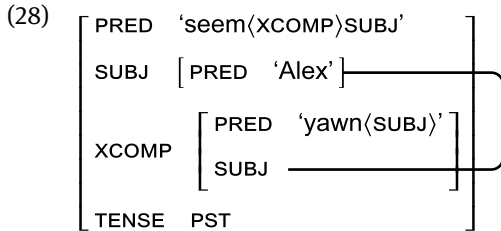

The parallel with the transformational raising analysis is clear: rather than saying that the subject of the lower clause has moved and now appears in the higher clause, the structure sharing analysis simply says that the two positions are identified with one another. In this case, the sharing is via lexical specification: it is a property of the verb *seem* that its subject is identified with the subject of its complement clause.

Long-distance dependencies are also handled at f-structure, without the need for traces or other empty nodes at c-structure. The f-structure for *What did Kim say you stole?* is given in (29):<sup>8</sup>

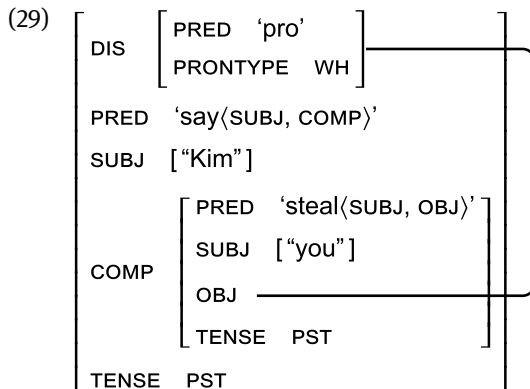

The fronted element, in this case a *wh*-proform, contributes the value of the attribute DIS (for ‘displaced element’) as well as of its *in situ* grammatical function. A special attribute DIS in the main clause is employed for two reasons: firstly, there is evidence that the displaced element plays a grammatical role in the main clause as well as in the subordinate one where it fills a gap (for example, in binding reflexives

<sup>7</sup> Note that because it is the *same* f-structure which appears as the value of both SUBJ and XCOMP SUBJ, no issue arises regarding the functional nature of  $\phi$ : the nodes are not projecting two different f-structures, one in each position, but rather a single f-structure which appears in both.

<sup>8</sup> The contents of f-structures can be abbreviated by enclosing the words that make them up in double inverted commas, just as we can conceal the internal structure of part of a phrase structure tree using a triangle.

in so-called ‘picture noun phrases’); secondly, by identifying the displaced element with a special attribute at f-structure, we allow for it to have a special role at other levels of representation: we license its fronting at c-structure by associating a specific phrase-structure position with the expression of the DIS attribute, for example. We also license its special role at information structure (i-structure), in this case ‘focus’, by associating the value of DIS, but not OBJECTS in general, with a special discourse function.

### 3.4 Crosslinguistic similarities and differences

As mentioned, LFG takes the level of representation which is most constant across languages to be f-structure. C-structure can vary widely, as attested by, among other things, the different word orders of the world’s languages. The nature of functional information is taken to be (largely) universal, whereas the means of mapping strings to that functional information is language-specific, albeit constrained by general factors: for example, the less morphology tells us about grammatical functions, the more constituent structure is likely to (and vice versa).

For the purposes of illustration, we give an example analysis of a sentence in Latin (30), which has relatively ‘free’ word order, and English (31), which is more configurational:

- (30) *Aciem instruxit legionum.*  
 line.ACC.SG arrange.PRF.3SG legions.GEN.PL  
 ‘He arranged a line of legions.’  
 (simplified from Caes. Gal. 1.24.2; for the full example, see Haug 2017, 124)

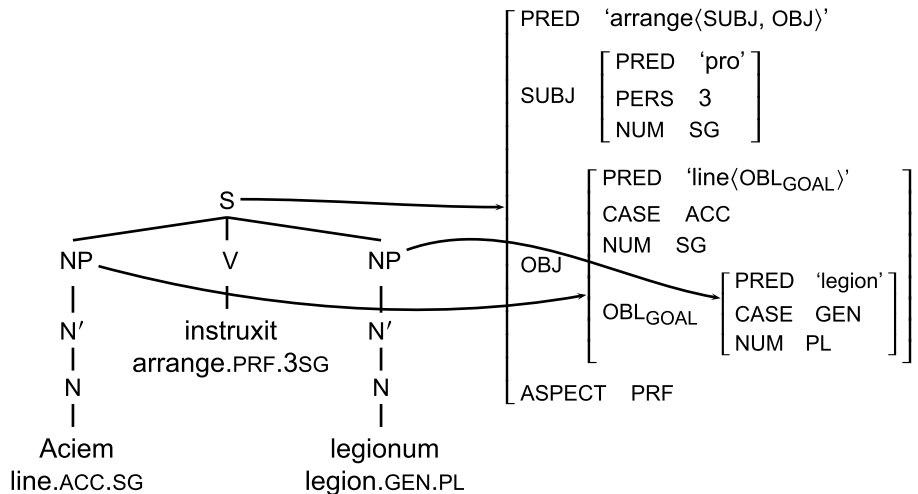

(31) 'He arranged a line of legions.'

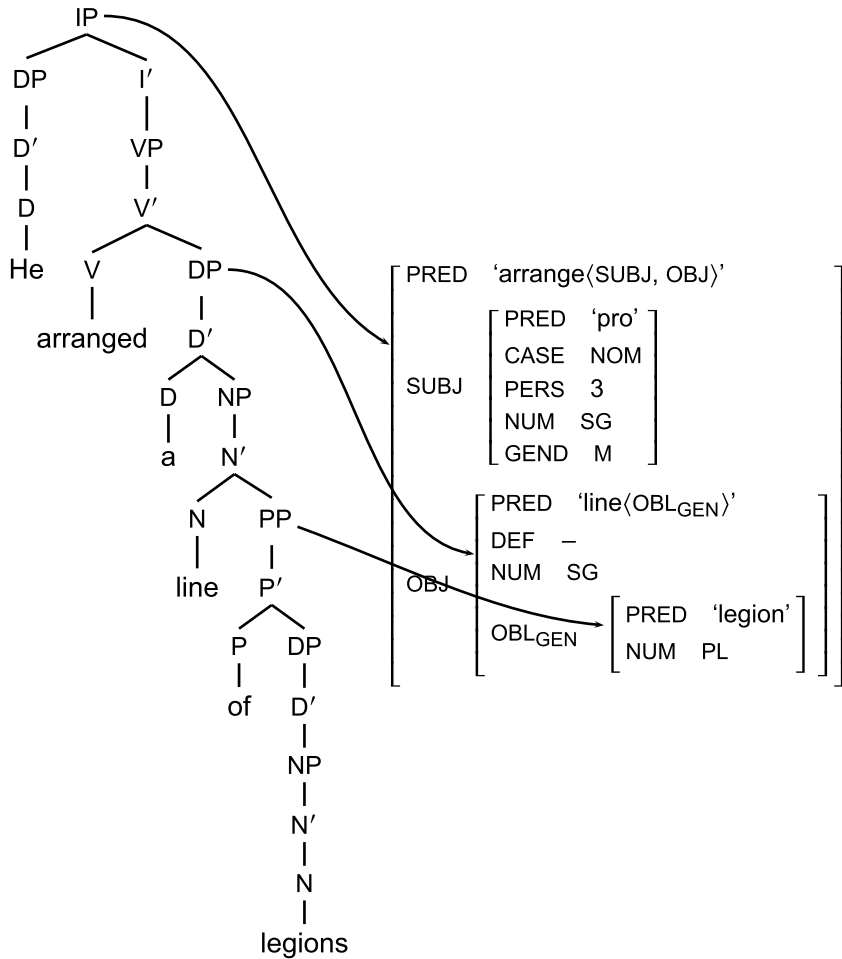

## 4 Evaluation

As in most linguistic theories, LFG accounts of linguistic phenomena are valued to the extent that they provide clear insight into the nature and properties of the phenomena. Evaluation of the relative merits of alternative accounts depends on their success at providing an accurate account of the data at all levels of structure. There is no requirement that constructions with similar meanings must have the same syntactic analysis crosslinguistically, but there is an expectation that there is a basic set of con-

cepts and theoretical vocabulary within each module that is useful for the analysis of all human languages. For example, all languages make use of grammatical functions drawn from the inventory given in Table 1. Similarly,  $X'$  theory is a part of the inventory of c-structure constraints available to all languages. However, languages need not have exclusively  $X'$ -theoretic categories, but may instead make extensive use of the exocentric category S, and may use only a subset of universally available c-structure categories.

The treatment of copula sentences offers an example of a point of theoretical debate within LFG. Dalrymple et al. (2004) argue that copular constructions can have different f-structure representations across languages and across constructions within the same language—they can be biclausal or monoclausal (often, but not always, conditioned by the presence or absence of an explicit copula verb), and if biclausal, can take an open or closed complement clause (XCOMP vs. PREDLINK). Attia (2008), on the other hand, argues for a unified analysis, whereby all copula constructions cross-linguistically are treated as involving PREDLINKS. He claims that the approach of Dalrymple et al. (2004) misses the underlying functional similarity, and incorrectly encodes c-structural variation in f-structure. The framework itself does not impose one analysis or the other, but is compatible with various theoretical treatments, which must be decided between based on other criteria such as empirical coverage or analytic efficacy.

Another example is the debate over the existence of traces. For transformationalist theories, something must occupy the canonical c-structure position of a displaced element, since this is how its within-clause grammatical function is ascertained (whether this ‘something’ is a trace *per se* or another kind of object, such as a subsequently deleted copy of the moved phrase). Since LFG separates out such functional information from the phrasal configuration, no such requirement is present in an LFG analysis: thus, c-structure terminals can be much closer to the observed linguistic data, and if something is not pronounced, it need not appear at c-structure. Nonetheless, traces can and have been used in LFG analyses of long-distance dependencies, as mentioned in Section 3.1 (e. g. Bresnan, 1995). Once again, therefore, the LFG framework itself remains agnostic about this particular theoretical question, and empirical factors, compatibility with analyses of related phenomena, and/or questions of parsimony will have to be the final arbiters.

## 4.1 Incrementality

It is a hallmark of constraint-based, nontransformational approaches like LFG that all grammatical constraints associated with the relevant words and constructions must be satisfied. Grammatical representations do not have different properties at different stages of a derivation, as in a transformational or other movement-based approach.

Instead, each constraint adds a piece of information about a structure or the relation between structures. As Halvorsen (1983) observes, “just as in a jigsaw puzzle, what piece is found at what time is inconsequential to the final outcome”. As a corollary of this, we can impose independent psycholinguistic restrictions on the order in which constraints are evaluated, without affecting the resulting analysis: for example, we can build up a structure incrementally, as the words of a sentence are encountered, or we can adopt a head-driven approach, building up the structure of heads first and then their arguments.

## 4.2 Simplicity

LFG factors grammatical analysis into modules: c-structure, f-structure, semantic structure, information structure, prosodic structure, and so on. The internal structure of each module is relatively simple, since it represents only one aspect of the structure of an utterance. This means that it is easy to isolate a module and explore only one aspect of its linguistic structure—c-structure, for example, or f-structure. Although modules do often interact, proposed changes in analysis that are confined to one module often leave the other modules unaffected, so that, for example, advances in our understanding of the semantics of a construction need not entail a revision to the theory of its syntax, and vice versa.

## 4.3 Mismatches

LFG assumes that different grammatical modules represent different aspects of grammatical structure, and mismatches between levels are common. For example, c-structure and f-structure have different units, motivated differently and representing different aspects of linguistic structure, and a linguistic unit at f-structure need not correspond to a c-structure unit: as shown in (17), the subject noun phrase translated as ‘these floods’ is represented as a unit at f-structure, but at c-structure the two parts of the phrase are separated, and do not form a unit. What is a unit at one level need not form a unit at all levels of representation.

## 5 Sample analysis

In this section, we provide a sample analysis of the sentence in (32):

- (32) After Mary introduced herself to the audience, she turned to a man that she had met before.



We first break the example sentence into two smaller sentences and provide detailed analyses of each of these, before combining them to give an analysis of the whole example in (35), which abbreviates some of the detail introduced in (33–34).

Two points should be noted in what follows. Firstly, in standard LFG analyses, intersentential and intrasentential coreference and binding are not represented at c-structure or f-structure, but instead in the semantics. Thus, the binding of the reflexive *herself* and the potential coreference of *Mary* and *she* are not represented in our analysis. Secondly, we are assuming a theory of adjunction where ‘like adjoins to like’ (Toivonen, 2003)—that is, zero-level categories can adjoin to other zero-level categories, and maximal projections to maximal projections. Since relative clauses are maximal projections, we therefore adjoin the CP ‘that she had met before’ at the level of NP (rather than N’, for example) in (34), and since the temporal adjunct ‘After Mary introduced herself to the audience’ is a CP, this is adjoined at the level of IP in (35).

(33) Mary introduced herself to the audience.

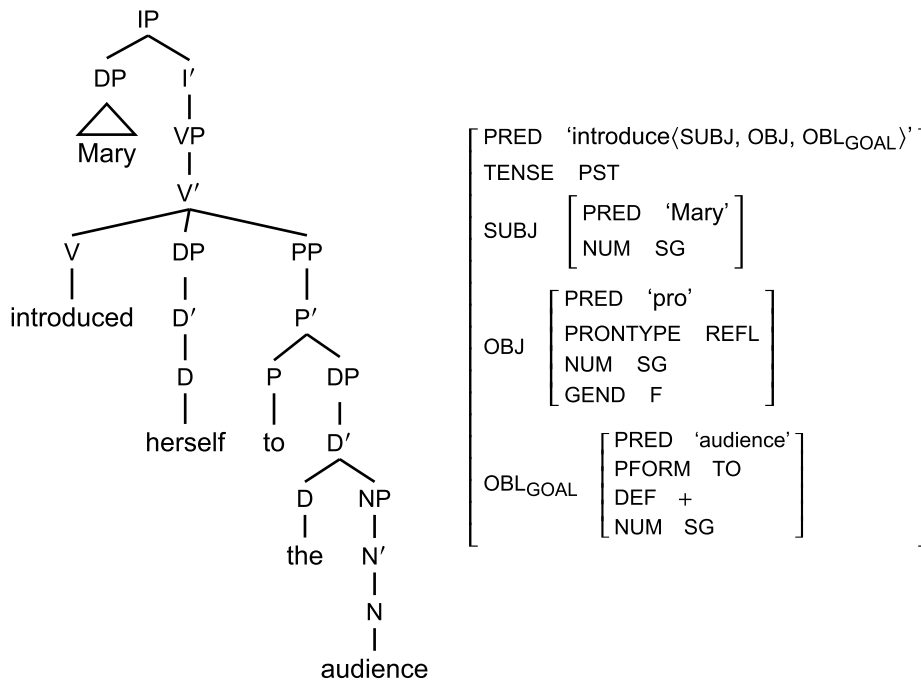

(34) She turned to a man that she had met before.

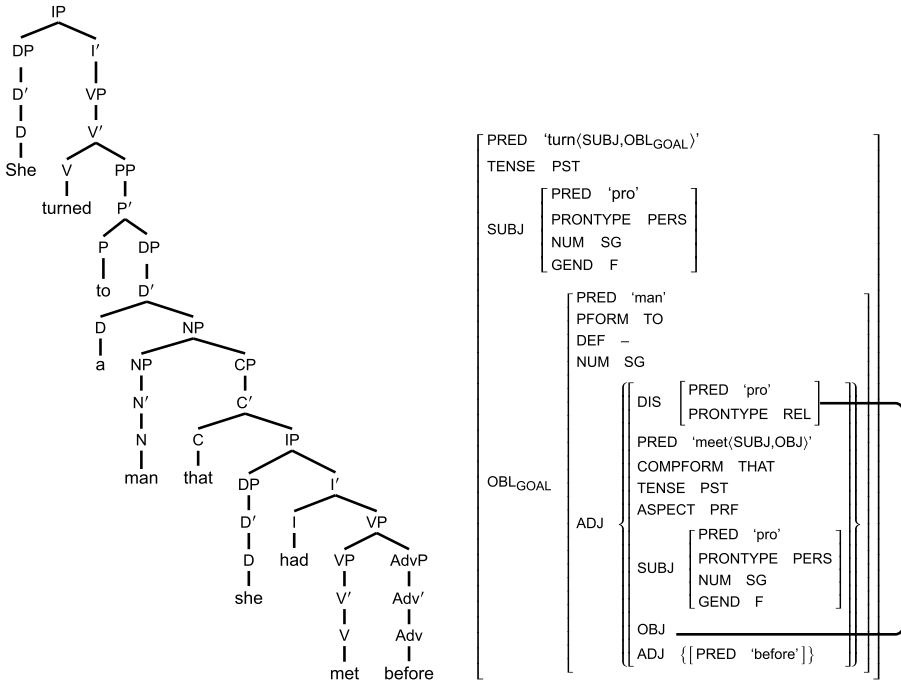

(35) After Mary introduced herself to the audience, she turned to a man that she had met before.

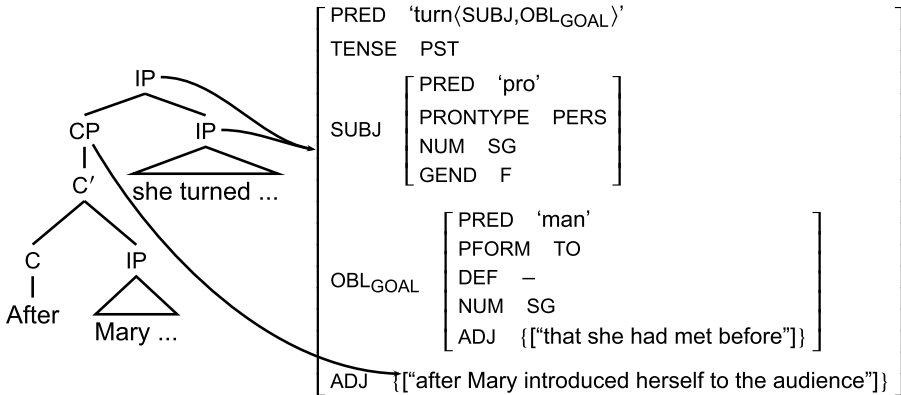

## 6 Conclusion

LFG has a number of appealing characteristics both in terms of theory and practice. Its mathematically explicit formalisation (exemplified in its successful computational

implementation) lends a precision to analyses which can be lost in other theories through appeals to metaphor or other intuitive devices. Its modularity enables parsimonious and accurate description of different phenomena using different formal tools, and this has the added practical advantage of allowing researchers to focus on one particular module without worrying unduly about all of the other components of the grammar simultaneously. This also makes it well-suited for use as a grammatical framework for other areas than purely theoretical syntax, such as in language acquisition in the form of LFG-DOP, or computational grammar development. Finally, its focus on accurate and precise description has made it possible to analyse a number of diverse languages without insisting on similarity where none is otherwise motivated (making non-configurational languages after all configurational at some level of representation, for example).

## References

- Allen, Cynthia. 1995. *Case marking and reanalysis: Grammatical relations from Old to Early Modern English*. Oxford: Clarendon Press.
- Allen, Cynthia. 2008. *Genitives in early English: Typology and evidence*. Oxford: Oxford University Press.
- Andrews, Avery D. 2006. Semantic composition for NSM, using LFG+Glue. In *Proceedings of the 2005 Conference of the Australian Linguistic Society*. URL <http://www.als.asn.au/proceedings/als2005/andrews-semantic.pdf>.
- Asudeh, Ash. 2006. Direct compositionality and the architecture of LFG. In Miriam Butt, Mary Dalrymple & Tracy Holloway King (eds.), *Intelligent Linguistic Architectures: Variations on Themes by Ronald M. Kaplan*, 363–387. Stanford: CSLI Publications.
- Asudeh, Ash. 2012. *The logic of pronominal resumption*. Oxford: Oxford University Press.
- Asudeh, Ash & Gianluca Giorgolo. 2012. Flexible composition for optional and derived arguments. In Miriam Butt & Tracy Holloway King (eds.), *On-Line Proceedings of the LFG2012 Conference*, 64–84. Stanford: CSLI Publications. URL <http://web.stanford.edu/group/cslipublications/cslipublications/LFG/17/lfg12.html>.
- Asudeh, Ash & Ida Toivonen. 2015. Lexical-Functional Grammar. In Bernd Heine & Heiko Narrog (eds.), *The Oxford Handbook of Linguistic Analysis*. 2nd edn. Oxford: Oxford University Press.
- Attia, Mohammed. 2008. A unified analysis of copula constructions in LFG. In Miriam Butt & Tracy Holloway King (eds.), *On-Line Proceedings of the LFG2008 Conference*, 89–108. Stanford: CSLI Publications. URL <http://web.stanford.edu/group/cslipublications/cslipublications/LFG/13/lfg08.html>.
- Austin, Peter & Joan Bresnan. 1996. Non-configurationality in Australian Aboriginal languages. *Natural Language and Linguistic Theory* 14(2). 215–268.
- Bary, Corien & Dag T. T. Haug. 2011. Temporal anaphora across and inside sentences: The function of participles. *Semantics and Pragmatics*. 4. article 8. 1–56.
- Berwick, Robert C. 1982. Computational complexity and Lexical-Functional Grammar. *American Journal of Computational Linguistics* 8. 97–109.
- Bettoni, Camilla & Bruno Di Biase (eds.). 2015. *Grammatical development in second languages: Exploring the boundaries of Processability Theory*. Italy: European Second Language Association.

- Bod, Rens. 1992. A computational model of language performance: Data Oriented Parsing. In *Proceedings of the 15th International Conference on Computational Linguistics* (Project notes with demonstrations 3), 855–859. International Committee on Computational Linguistics, Nantes, France: Association for Computational Linguistics. URL <http://aclweb.org/anthology/C92-3126>.
- Bod, Rens & Ronald M. Kaplan. 1998. A probabilistic corpus-driven model for Lexical-Functional analysis. In *COLING/ACL98: Joint Meeting of the 36th Annual Meeting of the ACL and the 17th International Conference on Computational Linguistics*, 145–151. Montréal: International Committee on Computational Linguistics.
- Börjars, Kersti, Pauline Harries & Nigel Vincent. 2016. Growing syntax: The development of a DP in Northern Germanic. *Language* 92(1). e1–e37.
- Börjars, Kersti & Nigel Vincent. 2016. Lexical-functional grammar. In Adam Ledgeway & Ian Roberts (eds.), *The Cambridge Handbook of Historical Syntax*. Cambridge, UK: Cambridge University Press.
- Börjars, Kersti, Nigel Vincent & Carol Chapman. 1997. Paradigms, periphrases and pronominal inflection: A feature-based account. In Geert Booij & Jaap van Marle (eds.), *Yearbook of Morphology*, 155–180. Dordrecht: Kluwer.
- Bresnan, Joan. 1978. A realistic transformational grammar. In Morris Halle, Joan Bresnan & George A. Miller (eds.), *Linguistic Theory and Psychological Reality*, 1–59. Cambridge, MA: The MIT Press.
- Bresnan, Joan. 1993. Interaction between grammar and discourse in Chicheŵa (Bantu). In William A. Foley (ed.), *The Role of Theory in Language Description* (Trends in Linguistics: Studies and Monographs), 45–60. Berlin: Mouton de Gruyter.
- Bresnan, Joan. 1995. Linear order, syntactic rank, and empty categories: On weak crossover. In Mary Dalrymple, Ronald M. Kaplan, John T. Maxwell III & Annie Zaenen (eds.), *Formal Issues in Lexical-Functional Grammar*, 241–274. Stanford: CSLI Publications.
- Bresnan, Joan. 1998. Morphology competes with syntax: Explaining typological variation in weak crossover effects. In Pilar Barbosa, Danny Fox, Paul Hagstrom, Martha McGinnis & David Pesetsky (eds.), *Is the Best Good Enough? Optimality and Competition in Syntax*, 59–92. MA, Cambridge: The MIT Press and MIT Working Papers in Linguistics. URL <https://web.stanford.edu/~bresnan/final-pub-rev.ps>. Also presented at the MIT Workshop on Optimality in Syntax, May 1995.
- Bresnan, Joan. 2000. Optimal syntax. In Joost Dekkers, Frank van der Leeuw & Jeroen van de Weijer (eds.), *Optimality Theory: Phonology, Syntax and Acquisition*, 334–385. Oxford: Oxford University Press. URL <http://www.stanford.edu/ProtectedTildeSymbolbresnan/pt3.pdf>.
- Bresnan, Joan. 2002. The lexicon in Optimality Theory. In Suzanne Stevenson & Paola Merlo (eds.), *The Lexical Basis of Syntactic Processing: Formal, Computational and Experimental Issues*, 39–58. Amsterdam: John Benjamins.
- Bresnan, Joan, Ash Asudeh, Ida Toivonen & Stephen Wechsler. 2016. *Lexical-Functional Syntax*. 2nd edn. Oxford: Wiley Blackwell.
- Bresnan, Joan & Jonni M. Kanerva. 1989. Locative inversion in Chicheŵa: A case study of factorization in grammar. *Linguistic Inquiry* 20(1). 1–50. Reprinted in Stowell and Wehrli (1992).
- Bresnan, Joan & Sam A. Mchombo. 1987. Topic, pronoun, and agreement in Chicheŵa. *Language* 63(4). 741–782.
- Butt, Miriam. 1995. *The structure of complex predicates in Urdu* (Dissertations in Linguistics). Stanford: CSLI Publications. Revised and corrected version of 1993 Stanford University dissertation.
- Butt, Miriam, Mary Dalrymple & Anette Frank. 1997. An architecture for linking theory in LFG. In Miriam Butt & Tracy Holloway King (eds.), *On-Line Proceedings of the LFG97 Conference*.

- Stanford: CSLI Publications. URL <http://web.stanford.edu/group/cslipublications/cslipublications/LFG/LFG2-1997/>.
- Butt, Miriam & Tracy Holloway King (eds.). 2001. *Time over matter: Diachronic perspectives on morphosyntax*. Stanford: CSLI Publications.
- Butt, Miriam & Tracy Holloway King. 2004. The status of case. In Veneeta Dayal & Anoop Mahajan (eds.), *Clause Structure in South Asian Languages*, 153–198. Dordrecht: Springer.
- Butt, Miriam, Tracy Holloway King, Hiroshi Masuichi & Christian Rohrer. 2002. The parallel grammar project. In J. Carroll, N. Oostijk & R. Sutcliffe (eds.), *Proceedings of the Workshop on Grammar Engineering and Evaluation*, 1–7. COLING02.
- Butt, Miriam, Tracy Holloway King, María-Eugenia Niño & Frédérique Segond. 1999. *A grammar writer's cookbook*. Stanford: CSLI Publications.
- Chaves, Rui P. 2018. Construction grammar. In András Kertész, Edith Moravcsik & Csilla Rákosi (eds.), *Current Approaches to Syntax: A Comparative Handbook*. De Gruyter Mouton.
- Coppock, Elizabeth & Stephen Wechsler. 2010. Less-travelled paths from pronoun to agreement: The case of the Uralic objective conjugations. In Miriam Butt & Tracy Holloway King (eds.), *On-Line Proceedings of the LFG2010 Conference*. Stanford: CSLI Publications. URL <http://web.stanford.edu/group/cslipublications/cslipublications/LFG/15/lfg10.html>.
- Crouch, Dick, Mary Dalrymple, Ronald M. Kaplan, Tracy Holloway King, John T. Maxwell III & Paula S. Newman. 2008. *XLE documentation*. Palo Alto Research Center, Palo Alto, CA. URL [http://www2.parc.com/isl/groups/nltxle/doc/xle\\_toc.html](http://www2.parc.com/isl/groups/nltxle/doc/xle_toc.html).
- Dalrymple, Mary (ed.). 1999. *Semantics and syntax in Lexical Functional Grammar: The resource logic approach*. Cambridge, MA: The MIT Press.
- Dalrymple, Mary. 2001. *Lexical Functional Grammar* (Syntax and Semantics, 34). New York: Academic Press.
- Dalrymple, Mary. 2015. Morphology in the LFG architecture. In Miriam Butt & Tracy Holloway King (eds.), *On-Line Proceedings of the LFG2015 Conference*. Stanford: CSLI Publications. URL <http://csli-publications.stanford.edu/LFG/20/lfg15.html>.
- Dalrymple, Mary, Helge Dyvik & Tracy Holloway King. 2004. Copular complements: Closed or open? In Miriam Butt & Tracy Holloway King (eds.), *On-Line Proceedings of the LFG2004 Conference*. Stanford: CSLI Publications. URL <http://csli-publications.stanford.edu/LFG/9/lfg04.html>.
- Dalrymple, Mary, Dag T. T. Haug & John J. Lowe. 2017. Integrating LFG's binding theory with PCDR. In Miriam Butt & Tracy Holloway King (eds.), *On-Line Proceedings of the LFG2017 Conference*. Stanford: CSLI Publications. URL <http://csli-publications.stanford.edu/LFG/22/lfg17.html>.
- Dalrymple, Mary, Ronald M. Kaplan & Tracy Holloway King. 2007. The absence of traces: Evidence from weak crossover. In Annie Zaenen, Jane Simpson, Tracy Holloway King, Jane Grimshaw, Joan Maling & Christopher Manning (eds.), *Architectures, Rules, and Preferences: Variations on Themes by Joan W. Bresnan*. Stanford: CSLI Publications.
- Dalrymple, Mary, Ronald M. Kaplan & Tracy Holloway King. 2015. Economy of expression as a principle of syntax. *Journal of Language Modelling* 2(3). 377–412. URL <http://jlm.ipipan.waw.pl/index.php/JLM/article/view/82>.
- Dalrymple, Mary, Ronald M. Kaplan, John T. Maxwell III & Annie Zaenen (eds.). 1995. *Formal issues in Lexical-Functional Grammar*. Stanford: CSLI Publications.
- Dalrymple, Mary, John J. Lowe & Louise Mycock. 2019. *The Oxford Reference Guide to Lexical Functional Grammar*. Oxford: Oxford University Press.
- Dalrymple, Mary & Louise Mycock. 2011. The prosody-syntax interface. In Miriam Butt & Tracy Holloway King (eds.), *On-Line Proceedings of the LFG2011 Conference*. Stanford: CSLI Publications. URL <http://web.stanford.edu/group/cslipublications/cslipublications/LFG/16/lfg11.html>.

- Dalrymple, Mary & Irina Nikolaeva. 2011. *Objects and information structure*. Cambridge, UK: Cambridge University Press.
- Dyvik, Helge, Paul Meurer, Victoria Rosén & Koenraad De Smedt. 2009. Linguistically motivated parallel parsebanks. In *Proceedings of the Eighth International Workshop on Treebanks and Linguistic Theories*. Milan: EDUCatt.
- Falk, Yehuda N. 2001. *Lexical-Functional Grammar: An introduction to parallel constraint-based syntax*. Stanford: CSLI Publications.
- Falk, Yehuda N. 2006. *Subjects and universal grammar: An explanatory theory*. Cambridge, UK: Cambridge University Press.
- Featherston, Sam. 2008. Thermometer judgements as linguistic evidence. In C. M. Riehl & A. Rothe (eds.), *Was ist linguistische Evidenz?* Aachen: Shaker Verlag.
- Findlay, Jamie Y. 2016. Mapping theory without argument structure. *Journal of Language Modelling* 4(2). 293–338. URL <http://jlm.ipipan.waw.pl/index.php/JLM/article/view/171/0>.
- Giorgolo, Gianluca & Ash Asudeh. 2011. Multimodal communication in LFG: Gestures and the correspondence architecture. In Miriam Butt & Tracy Holloway King (eds.), *On-Line Proceedings of the LFG2011 Conference*, 257–277. Stanford: CSLI Publications. URL <http://web.stanford.edu/group/cslipublications/cslipublications/LFG/16/lfg11.html>.
- Goddard, Cliff & Anna Wierzbicka. 2002. *Meaning and universal grammar: Theory and empirical findings*. John Benjamins. Two volumes.
- Halvorsen, Per-Kristian. 1983. Semantics for Lexical Functional Grammar. *Linguistic Inquiry* 14(4). 567–615.
- Haug, Dag T. T. 2017. Backward control in Ancient Greek and Latin participial adjuncts. *Natural Language and Linguistic Theory* 35(1). 99–159.
- Hornstein, Norbert. 1995. *Logical Form: From GB to Minimalism*. Oxford: Blackwell.
- Hornstein, Norbert. 2018. The minimalist programme. In András Kertész, Edith Moravcsik & Csilla Rákosi (eds.), *Current Approaches to Syntax: A Comparative Handbook*. De Gruyter Mouton.
- Jackendoff, Ray. 1977. *X̄ syntax: A study of phrase structure*. Cambridge, MA: The MIT Press.
- Jackendoff, Ray & Jenny Audring. 2018. The parallel architecture. In András Kertész, Edith Moravcsik & Csilla Rákosi (eds.), *Current Approaches to Syntax: A Comparative Handbook*. De Gruyter Mouton.
- Joshi, Aravind K. 1985. Tree adjoining grammars: How much context-sensitivity is required to provide reasonable structural descriptions? In David R. Dowty, Lauri Karttunen & Arnold M. Zwicky (eds.), *Natural Language Parsing*, 206–250. Cambridge University Press.
- Kaplan, Ronald M. 1987. Three seductions of computational psycholinguistics. In Peter Whitelock, Mary McGee Wood, Harold L. Somers, Rod Johnson & Paul Bennett (eds.), *Linguistic Theory and Computer Applications*, 149–188. London: Academic Press. Also published as CCL/UMIST Report No. 86.2: Alvey/ICL Workshop on Linguistic Theory and Computer Applications: Transcripts of Presentations and Discussions. Center for Computational Linguistics, University of Manchester. Reprinted in Dalrymple et al. (1995, 337–367).
- Kaplan, Ronald M. & Joan Bresnan. 1982. Lexical-Functional Grammar: A formal system for grammatical representation. In Joan Bresnan (ed.), *The Mental Representation of Grammatical Relations*, 173–281. Cambridge, MA: The MIT Press. Reprinted in Dalrymple et al. (1995, 29–130).
- Kaplan, Ronald M. & Miriam Butt. 2002. The morphology-syntax interface in LFG. URL <http://cslipublications.stanford.edu/LFG/7/lfg02.html>. Abstract in *On-Line Proceedings of the LFG2002 Conference*, Miriam Butt & Tracy Holloway King (eds.).
- Kaplan, Ronald M. & John T. Maxwell III. 1996. LFG grammar writer's workbench. Technical report, Xerox Palo Alto Research Center, Palo Alto, CA. URL <http://www2.parc.com/isl/groups/nlft/medley/>.

- Kaplan, Ronald M., John T. Maxwell III & Annie Zaenen. 1987. Functional uncertainty. In *CSLI Publications Monthly Newsletter*. Stanford University.
- Kaplan, Ronald M. & Annie Zaenen. 1989. Long-distance dependencies, constituent structure, and functional uncertainty. In Mark Baltin & Anthony S. Kroch (eds.), *Alternative Conceptions of Phrase Structure*, 17–42. Chicago: University of Chicago Press. Reprinted in Dalrymple et al. (1995, 137–165).
- Kayne, Richard S. 1984. *Connectedness and binary branching*. Dordrecht: Foris.
- Kibort, Anna. 2004. Passive and passive-like constructions in English and Polish. Ph.D. thesis, University of Cambridge.
- King, Tracy Holloway & Annie Zaenen. 2004. F-structures, information structure, and discourse structure. Christchurch, New Zealand: University of Canterbury. Presented at the *Winter School in LFG and Computational Linguistics*. URL <http://cslipublications.stanford.edu/LFG/9/lfg04kingzaenen-abs.html>.
- Kroeger, Paul. 1993. *Phrase structure and grammatical relations in Tagalog* (Dissertations in Linguistics). Stanford: CSLI Publications. Revised and corrected version of 1991 Stanford University dissertation.
- Kuhn, Jonas. 2001. Formal and computational aspects of Optimality-Theoretic syntax. Ph.D. thesis, Universität Stuttgart.
- Legendre, Géraldine. 2018. Optimality theoretical syntax. In András Kertész, Edith Moravcsik & Csilla Rákosi (eds.), *Current Approaches to Syntax: A Comparative Handbook*. De Gruyter Mouton.
- Lowe, John J. 2012. The syntax and semantics of tense-aspect stem participles in Early R̥gvedic Sanskrit. D.Phil. thesis. University of Oxford.
- Maxwell, John T. III. 2015. XLE. URL <http://www2.parc.com/isl/groups/nlft/xle/>.
- May, Robert. 1985. *Logical form: Its structure and derivation*. Cambridge, MA: The MIT Press.
- McCawley, James D. 1968. Concerning the base component of a transformational grammar. *Foundations of Language* 4. 243–269. Reprinted in McCawley (1973).
- McCawley, James D. 1973. *Grammar and meaning: Papers on syntactic and semantic topics*. Tokyo: Taishukan.
- Müller, Stefan & Antonio Machicao y Priemer. 2018. Head-driven phrase structure grammar. In András Kertész, Edith Moravcsik & Csilla Rákosi (eds.), *Current Approaches to Syntax: A Comparative Handbook*. De Gruyter Mouton.
- Mycock, Louise & John J. Lowe. 2013. The prosodic marking of discourse functions. In Miriam Butt & Tracy Holloway King (eds.), *On-Line Proceedings of the LFG2013 Conference*. Stanford: CSLI Publications. URL <http://web.stanford.edu/group/cslipublications/cslipublications/LFG/18/lfg13.html>.
- Nespor, Marina & Irene Vogel. 1986. *Prosodic phonology*. Dordrecht: Foris.
- Patejuk, Agnieszka & Adam Przepiórkowski. 2015. Parallel development of linguistic resources: Towards a structure bank of Polish. *Prace Filologiczne* 65. 255–270. URL <https://www.ceeol.com/search/viewpdf?id=307372>.
- Pienemann, Manfred. 1998. *Language processing and second language development: Processability theory*. Amsterdam: John Benjamins.
- Pienemann, Manfred (ed.). 2005. *Cross-linguistic aspects of Processability Theory* (Studies in Bilingualism, 30). Amsterdam: John Benjamins.
- Prince, Alan & Paul Smolensky. 2004. *Optimality Theory: Constraint interaction in generative grammar*. Oxford: Blackwell.
- Sadler, Louisa & Andrew Spencer. 2001. Syntax as an exponent of morphological features. In Geert Booij & Jaap van Marle (eds.), *Yearbook of Morphology*, 71–96. Dordrecht: Kluwer.
- Schachter, Paul. 1976. The subject in Philippine languages: Topic, actor, actor-topic, or none of the above. In Charles N. Li (ed.), *Subject and Topic*. New York: Academic Press.

- Selkirk, Elisabeth O. 1981. On the nature of phonological representation. In Terry Myers, John Laver & John Anderson (eds.), *The Cognitive Representation of Speech*, 379–388. Amsterdam: North Holland.
- Simon, Herbert A. 1962. The architecture of complexity. *Proceedings of the American Philosophical Society* 106(6). 467–482.
- Snijders, Liselotte. 2015. The nature of configurationality in LFG. D.Phil. thesis. University of Oxford.
- Spevak, Olga. 2010. *Constituent order in classical Latin prose* (Studies in Language Companion Series, 117). John Benjamins.
- Stowell, Timothy & Eric Wehrli (eds.). 1992. *Syntax and the lexicon* (Syntax and Semantics, 26). San Diego: Academic Press.
- Toivonen, Ida. 2003. *Non-projecting words: A case study of Swedish verbal particles*. Dordrecht: Kluwer.
- van Genabith, Josef & Richard Crouch. 1999. Dynamic and underspecified semantics for LFG. In Mary Dalrymple (ed.), *Semantics and Syntax in Lexical Functional Grammar: The Resource Logic Approach*. Cambridge, MA: The MIT Press.
- Vincent, Nigel. 1999. The evolution of c-structure: Prepositions and PPs from Indo-European to Romance. *Linguistics* 37(6). 1111–1153.
- Wedekind, Jürgen & Ronald M. Kaplan. 2019. Tractable Lexical-Functional Grammar. Submitted.